

NOTE: 1
 DESIGN CODE:
 N/A

NOTE: 2
 TECHNICAL CLASSIFICATION:
 Article Type: 003-Valve Stabs
 Main Group: 3.00. Misc-Valvestab
 Intermediate Group: 3.40.09. Spares
 Sub Group: 3.40.94.2. Receptacle

NOTE: 3
 INTERFACE INFORMATION:
 Pressure Rating Bar: N/A
 Material: TITAN G5
 Weight: 0 kg
 Volume: 0 dm³
 Surface Area: 26 cm²
 Hydraulic: N/A
 Mechanical: N/A
 Electrical: N/A
 Com. & Protocol: N/A

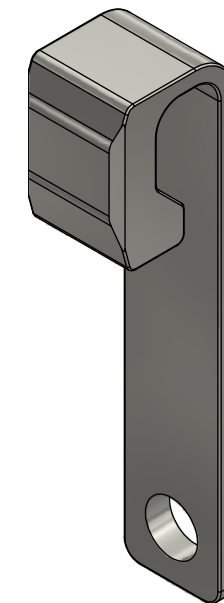
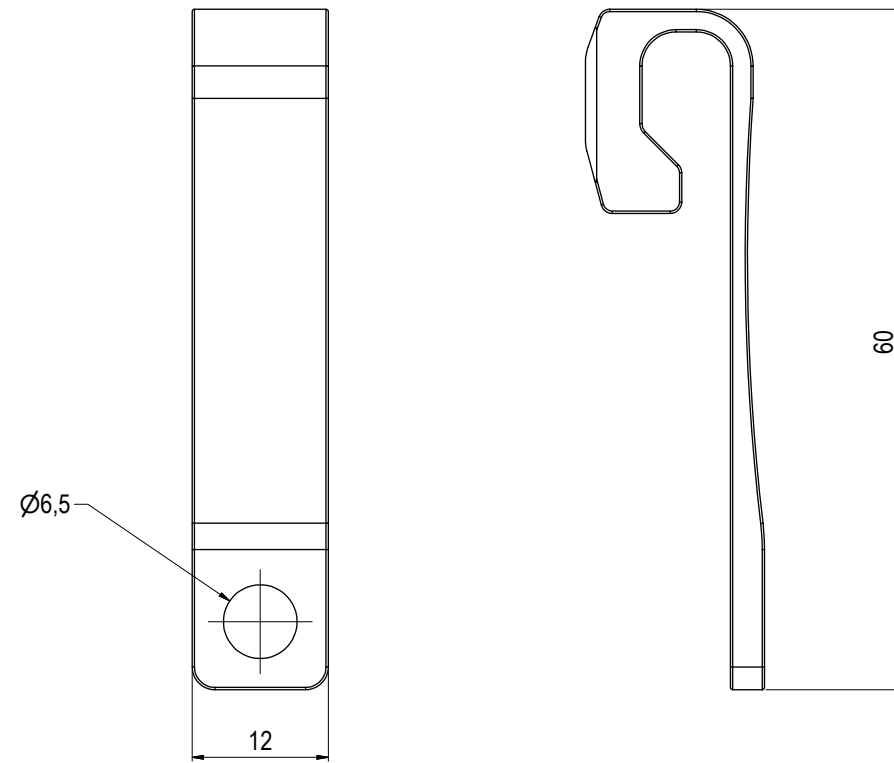

05	29.1.2019	7-IFC (Issued for Construction)		WTJ	BHB	WTJ
04	15.8.2016	7-IFC (Issued for Construction)		WTJ	LGH	WTJ
03	27.8.2013	7-IFC (Issued for Construction)		LGH	HNJ	LGH
02	6.12.2011	Issued for Construction		LGH	EKJ	HSE
Rev.	Date	Reason for issue	Revision change	Made	Chk'd	Appr.



Unless Noted Otherwise:
 Dim. Tol: NS-ISO 2768-1/N/A
 Roughness: RaN/A
 Fillet Rad: Corner Rmax: N/A

Dwg. Scale: NTS
 Dwg. Proj:
 Dwg. Format: A3
 Break Edges: (R. Alt. 45°) R= 0,1-0,5

Drawing title: Spring for Lock Function VStab Rec
 Drawing number: BA1954